



TECHNISCHER HANDEL BECKEL
LABORGERÄTE-SPEZIALGERÄTE-VERSCHLEISSTEILE-ERSATZTEILE

Instructions

Pailmixer

- type Beckel EM 20 (230 V / 400 V)**
- type Beckel EM 20 Z with time control (230V/400V)**
- type Beckel EM FU with speed control**
- type Beckel EM FUZ with speed control and time control**

!!! Caution - Before switching on read instructions !!!

<u>Contents:</u>		Side
1.	Safety warning	2
2.	Uses	3
3.	Technical Data	3
4.	Operation	4
5.	Cleaning	5
6.	Maintenance	5
7.	Spare part list	5
8.	Wiring diagram	6, 7
9.	Declaration of EC Conformity	8

Construction





TECHNISCHER HANDEL BECKEL
LABORGERÄTE-SPEZIALGERÄTE-VERSCHLEISSTEILE-ERSATZTEILE

1. Safety hints

Our small mixers are built using state-of-the-art technology and are quite safe with proper use.

The manufacturers refuse liability for damage resulting from unauthorised alterations.

The appliance may only be used for the correct purpose and by properly trained personnel. The personnel involved in the installation, maintenance and service of the appliance should have studied the official operational instructions.



Disconnect from mains before:

- Moving or transportation ,
- Cleaning, maintenance, and repairs
- Opening of the engine casing

Caution!

Keep hands and objects away from the rotating drum during mixing.

Before you switch on the mixer, ensure that the bucket handles are down.

The operational safety of the mixer is only guaranteed, when original spare parts (special pails, etc), are used.

The mixing tools of Pailmixer are set to the plastic bucket. When using the stainless steel bucket must be adjusted for optimum mixing results may restart.

Safety features

Transportation lock:

The transportation lock is positioned above the safety switch and should be secured before transportation. (reinforcement of the holding clamp of the mixer)

Safety switch:

In the event of a power failure, the safety switch is activated. When power is restored, use safety switch to start. (Automatic start is not possible).



If defects or damage affecting the egg mixer jeopardise operational safety, the unit must be taken out of operation immediately and not be used again until all safety hazards have been eliminated.

Use of a RESIDUAL-CURRENT-OPERATED CIRCUIT BREAKER with 30 mA rated tripping current is recommended.

Repairs to electrical parts of the machine must be carried out by the manufacturer or by a company nominated by the manufacturer.



TECHNISCHER HANDEL BECKEL
LABORGERÄTE-SPEZIALGERÄTE-VERSCHLEISSTEILE-ERSATZTEILE

2. Usage

The mixer is designed for mixing concrete, mortar, and similar mixtures.
The mixer is a laboratory device and is designed for mixing concrete, mortar, bulk materials and the like mix.
It may solely for testing and development work on building materials above Type are used.



Caution: Use no explosive, combustible materials or foodstuffs!

Improper use

Furthermore, the following activities do not constitute proper use and are therefore not permitted:

- Use of mixing vessels, which do not conform to the manufacturer's specification
- Unauthorised attaching of mixing tools and spares that are not original parts

Residual risks

Even when used appropriately and in conformance with all relevant safety provisions, there might be some residual risks due to the design for the intended purpose:

- Hazard from electrical power, if used with connection cables that do not conform to appropriate requirements.
- Contact with live parts when electrical components are exposed.
- Furthermore, there might be residual risks that are not obvious in spite of all precautions taken. Protection against the hazard of items being caught or wound up by the rotating mixing vessel is not practicable.
- Residual risks can be minimised by observing the operating instructions, safety guidelines and appropriate use.

3. Technical data

<input type="checkbox"/> weight:	approx.	39 kg
<input type="checkbox"/> measurements approx.:	width	430 mm
	depth	450 mm
	height	1250 mm
<input type="checkbox"/> connection:	230 V / 0,75 kW / 50 Hz	
<input type="checkbox"/> total volume of vessel:	20 l The effective filling quantity is dependent on the respective composition and consistency of the mixture	
<input type="checkbox"/> Capacity:	approx. 9 -11 l (low consistency concrete). The effective capacity depends on the respective composition and consistency of the material(s) being mixed	
Protection type	IP 55	
- Use with time control:		
Time range:	1 – 10 min If shorter times are required, the mixer can be manually switched off using the safety switch.	
- Use with speed control:		
Speed range:	15 – 50 rp	



TECHNISCHER HANDEL BECKEL
LABORGERÄTE-SPEZIALGERÄTE-VERSCHLEISSTEILE-ERSATZTEILE

4. Operation

- Before use, the mixer should be placed on a solid and level base.
- The drum should not contain any foreign objects!
- The frame assembly must be fully located onto the drive unit.
- The work area is to be secured from unauthorised persons.
- Mixer only to be used for purposes described in section 2.

1. Fill only when drum is stationary
2. Plug into suitable socket,
 - onl THB EM 20 Z - set time - use safety switch
 - on THB EM FU set desired speed
 - on THB EM FUZ set desired speed and time

Actuate circuit breaker

- Mixer with three-phase motor:
Observe direction of rotation - see below

Should a blocking of the mixing vessel be observed (e.g. due to strongly compacted or setting concrete or due to foreign body), the mixer must be switched off immediately (potential mechanical and motor damage)

3. Mix until the required consistency is achieved.
The skimmer attachment can be used to achieve optimal results.
4. Removal of the mixture **after turning off** the mixer:
 - either directly by means of shovel from the pail or
 - by releasing the frame assembly from the drive and removing drum.
 - The frame assembly can be withdrawn after opening of the transport lock.



Concrete mixer with three-phase motor 400 Volt

After switching the machine on, the direction of rotation of the mixing vessel must be checked. It must rotate from right to left (arrow indicating direction of rotation on front of mixer). If the mixing vessel is rotating against the direction indicated by the arrow you can change the direction of rotation by inserting a screwdriver into the slot on the connector shroud provided for this purpose, pushing in gently and turning clockwise or counter-clockwise (through 180°).





TECHNISCHER HANDEL BECKEL
LABORGERÄTE-SPEZIALGERÄTE-VERSCHLEISSTEILE-ERSATZTEILE

5. Cleaning

Clean the mixer of all the concrete and mortar as soon as possible after use.

CAUTION! Before cleaning – disconnect mains!

Do **n o t** immerse or spray mixer with water
Soiled areas are to be cleaned using a damp rag/cloth and brush.

The frame assembly and the drum can be cleaned with water after being separated from the motor.

6. Maintenance

Inspect all components regularly, particularly the screw-connection. Check oil levels with every use. Faults should be remedied immediately.

The engine oil capacity is 0,8 l. This should be changed after approximately 1000 operating hours.

Mix-tools and drum should be inspected regularly for wear and if necessary replaced.

7. Part list

Description	Order-No.
Drum, 20l	10-00236
Drum, 20l, stainless steel	20-00021
Mixing blade	20-00028
Skimmer – outside wall	20-00027
Skimmer – attachment	20-00029
Transportation lock	30-00051
Safety switch	30-00032
Wheels	30-00045

General hints

Please contact us directly should you have problems regarding service or function. We will be grateful for any suggestions you may have for the improvement of this mixer.

Our address:

THB Technischer Handel Beckel
Schwarzbacher Allee 3
98590 Schwallungen / Germany
Telefon +49 (0) 36848 – 25929 - 0
Telefax +49 (0) 36848 – 25929 - 90
info@thb-beckel.de
www.thb-beckel.de

8. Wiring diagram

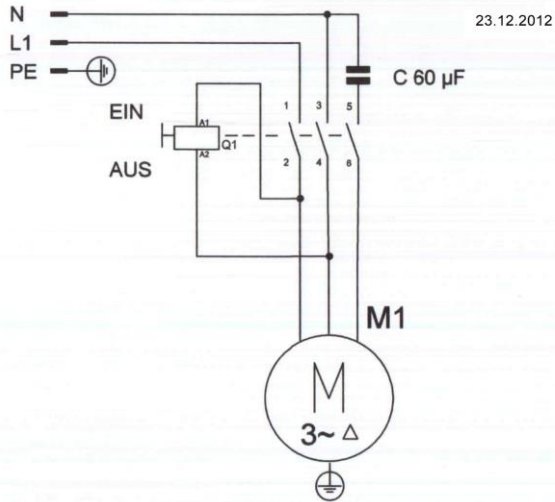

Mischer Einphasenanschluß 230V

770 W 50UpM einfache Ausführung

20-00020

Type THB EM 20 Z with time control

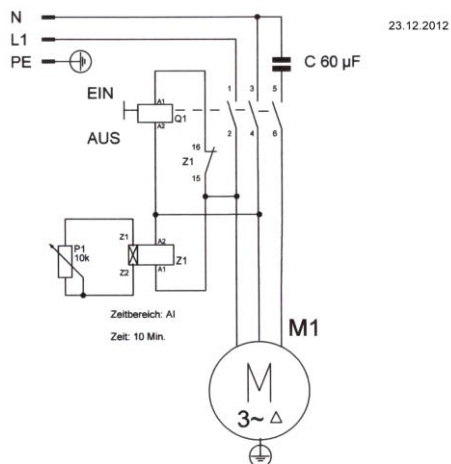

Mischer Einphasenanschluß 230V

770 W 50UpM einfache Ausführung mit Zeitrelais

20-00024



TECHNISCHER HANDEL BECKEL
LABORGERÄTE-SPEZIALGERÄTE-VERSCHLEISSTEILE-ERSATZTEILE

Type THB EM FUZ with speed control and time control

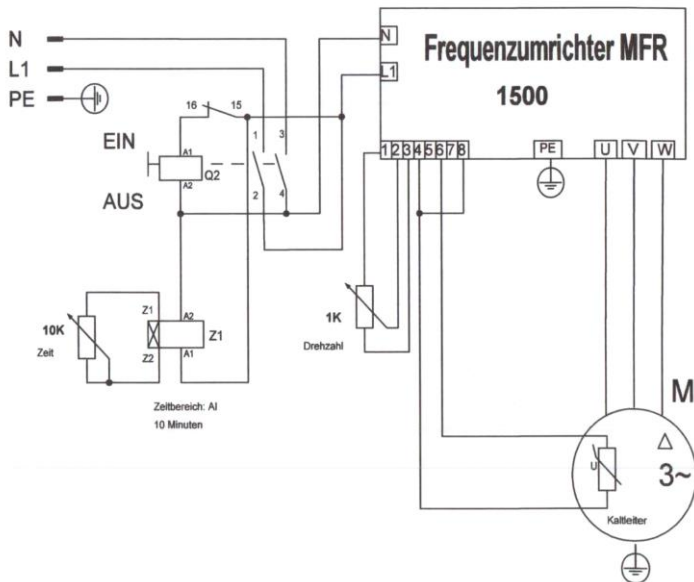

Mischer Einphasenanschluß 230V

770 W 36UpM FUZ

20-00026

23.12.2012

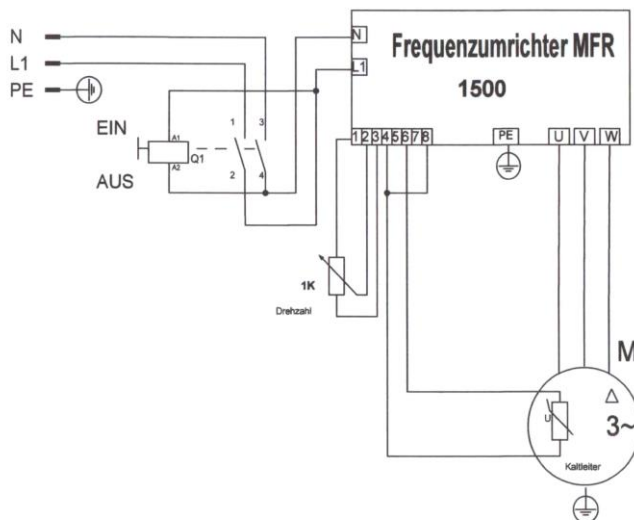

Mischer Einphasenanschluß 230V

770 W 36UpM FU

20-00025

23.12.2012



TECHNISCHER HANDEL BECKEL
LABORGERÄTE-SPEZIALGERÄTE-VERSCHLEISSTEILE-ERSATZTEILE

DECLARATION OF EC CONFORMITY

producer: *Technischer Handel Beckel
Schwarzbacher Allee 3
98590 Schwallungen
Germany*

**commissioner
for compilation
technical brochures:** *Thomas Beckel
proprietier
Technischer Handel Beckel
Schwarzbacher Allee 3
98590 Schwallungen
Germany*

name machine: *Mixer*

Machine type: *Pailmixer Beckel | 20-00020
Beckel EM 20 Z with time control 20-00024
Beckel EM FU with speed control 20-00025
Beckel EM FUZ with speed control and time
control 20-00026*

Serial number: *continuous*

We hereby declare that the design and construction of the following production model corresponds to the pertinent basic safety and health requirements of the EC guidelines. This declaration loses its validity by unauthorized alteration to the machine.

Pertinent

EC – machine guideline 2006/42/EC

EC – low voltage guideline 2014/35/EU

The following harmonized standards have been applied:

EN ISO 12100-1: 2003 / A1: 2009, Safety of machinery - Basic concepts, general principles for design
Part 1: Basic terminology, methodology

EN ISO 12100-2: 2003 / A1: 2009, Safety of machinery - Basic concepts, general principles for design
- Part 2: Technical principles

Schwallungen, 10.04.2017

Thomas Beckel, proprietier